

## STOVE MAINTENANCE

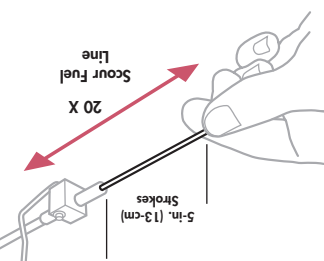

**9. Reassemble stove.**  
If stove performance is still impaired, repeat cleaning the jet and fuel line steps.  
is complete.  
Safely dispose fuel when flushing  
Close Control Valve and remove Fuel Line.  
ignition sources.  
WARNING: Keep away from  
(jet uninstalled.)  
Fully open Control Valve to flush  
4 spoonfuls of fuel through Fuel Line  
Pressurize Fuel Bottle with 15 strokes.  
Groove.  
and secure Catch Arm on Fuel Pump  
Insert Fuel Line into Pump and Fuel Bottle  
Remove Cable.  
Flush Fuel Line.  
Wipe Cable clean.  
Move Cable in and out with 5-inch  
(1.3-cm) strokes approximately 20 times.  
Fully reinsert Cable into Fuel Line.  
Shaker Needle inside Jet should rattle.  
Preheat and run stove.  
If performance does not improve, perform  
Cleaning the Jet and Fuel Line steps.

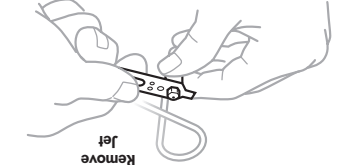

**1. Scour Fuel Line.**  
Remove Cable from Fuel Line with  
Jet and Cable tool. Shubborn cables  
can be loosened with a common  
lubricant (WD-40™, Pump Cup Oil, etc.).  
Fully reinsert Cable into Fuel Line.  
Move Cable in and out with 5-inch  
(1.3-cm) strokes approximately 20 times.  
Wipe Cable clean.  
Flush Fuel Line.  
Remove Cable.  
Insert Fuel Line into Pump and Fuel Bottle  
and secure Catch Arm on Fuel Pump  
Pressurize Fuel Bottle with 15 strokes.  
Fully open Control Valve to flush  
4 spoonfuls of fuel through Fuel Line  
into an appropriate container.  
Safely dispose fuel when flushing  
is complete.  
WARNING: Keep away from  
ignition sources.  
Close Control Valve and remove Fuel Line.  
Remove Cable.  
Flush Fuel Line.  
Wipe Cable clean.  
Move Cable in and out with 5-inch  
(1.3-cm) strokes approximately 20 times.  
Fully reinsert Cable into Fuel Line.  
Shaker Needle inside Jet should rattle.  
Preheat and run stove.  
If performance does not improve, perform  
Cleaning the Jet and Fuel Line steps.

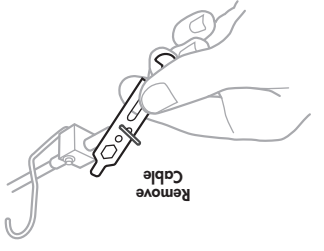

**8. Flush Fuel Line.**  
Remove Cable.  
Insert Fuel Line into Pump and Fuel Bottle  
and secure Catch Arm on Fuel Pump  
Pressurize Fuel Bottle with 15 strokes.  
Fully open Control Valve to flush  
4 spoonfuls of fuel through Fuel Line  
into an appropriate container.  
Safely dispose fuel when flushing  
is complete.  
WARNING: Keep away from  
ignition sources.  
Close Control Valve and remove Fuel Line.  
Remove Cable.  
Flush Fuel Line.  
Wipe Cable clean.  
Move Cable in and out with 5-inch  
(1.3-cm) strokes approximately 20 times.  
Fully reinsert Cable into Fuel Line.  
Shaker Needle inside Jet should rattle.  
Preheat and run stove.  
If performance does not improve, perform  
Cleaning the Jet and Fuel Line steps.

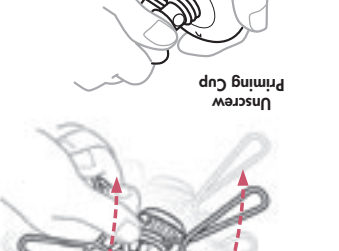

**7. Scour Fuel Line.**  
Remove Cable from Fuel Line with  
Jet and Cable tool. Shubborn cables  
can be loosened with a common  
lubricant (WD-40™, Pump Cup Oil, etc.).  
Fully reinsert Cable into Fuel Line.  
Move Cable in and out with 5-inch  
(1.3-cm) strokes approximately 20 times.  
Wipe Cable clean.  
Flush Fuel Line.  
Remove Cable.  
Insert Fuel Line into Pump and Fuel Bottle  
and secure Catch Arm on Fuel Pump  
Pressurize Fuel Bottle with 15 strokes.  
Fully open Control Valve to flush  
4 spoonfuls of fuel through Fuel Line  
into an appropriate container.  
Safely dispose fuel when flushing  
is complete.  
WARNING: Keep away from  
ignition sources.  
Close Control Valve and remove Fuel Line.  
Remove Cable.  
Flush Fuel Line.  
Wipe Cable clean.  
Move Cable in and out with 5-inch  
(1.3-cm) strokes approximately 20 times.  
Fully reinsert Cable into Fuel Line.  
Shaker Needle inside Jet should rattle.  
Preheat and run stove.  
If performance does not improve, perform  
Cleaning the Jet and Fuel Line steps.



**6. Remove Shaker Needle and use it to clear Jet Orifice from top or bottom.**  
Needle in new Jet and reassemble stove.  
Remove Cable from Fuel Line with  
Jet and Cable tool. Shubborn cables  
can be loosened with a common  
lubricant (WD-40™, Pump Cup Oil, etc.).  
Fully reinsert Cable into Fuel Line.  
Move Cable in and out with 5-inch  
(1.3-cm) strokes approximately 20 times.  
Wipe Cable clean.  
Flush Fuel Line.  
Remove Cable.  
Insert Fuel Line into Pump and Fuel Bottle  
and secure Catch Arm on Fuel Pump  
Pressurize Fuel Bottle with 15 strokes.  
Fully open Control Valve to flush  
4 spoonfuls of fuel through Fuel Line  
into an appropriate container.  
Safely dispose fuel when flushing  
is complete.  
WARNING: Keep away from  
ignition sources.  
Close Control Valve and remove Fuel Line.  
Remove Cable.  
Flush Fuel Line.  
Wipe Cable clean.  
Move Cable in and out with 5-inch  
(1.3-cm) strokes approximately 20 times.  
Fully reinsert Cable into Fuel Line.  
Shaker Needle inside Jet should rattle.  
Preheat and run stove.  
If performance does not improve, perform  
Cleaning the Jet and Fuel Line steps.

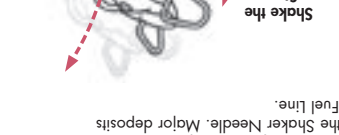

**5. Unscrew Jet with Jet and Cable Tool.**  
Legs together.  
Rescrew Priming Cup to keep Pot Supports/  
Legs together.  
Remove Fuel Line from Mixer Tube.  
Keep unattached Fuel Line threaded  
through leg.  
Hold folded Pot Supports/Legs together.  
Unscrew Priming Cup and remove Wick.  
Fold Pot Supports/Legs to packed position.  
Cleaning the Jet and Fuel Line steps.



**4. Rescrew Priming Cup to keep Pot Supports/Legs together.**  
Remove Fuel Line from Mixer Tube.  
Keep unattached Fuel Line threaded  
through leg.  
Hold folded Pot Supports/Legs together.  
Unscrew Priming Cup and remove Wick.  
Fold Pot Supports/Legs to packed position.  
Cleaning the Jet and Fuel Line steps.



**3. Preheat and run stove.**  
If performance does not improve, perform  
Cleaning the Jet and Fuel Line steps.  
Shake the  
Stove  
5 minutes for stove to cool.  
Use Pump Control Valve and wait  
for stove to cool.  
Shake stove up and down.  
Shaker Needle inside Jet should rattle.  
Preheat and run stove.  
If performance does not improve, perform  
Cleaning the Jet and Fuel Line steps.



**2. Unscrew Pump Control Valve and wait for stove to cool.**  
Shake stove up and down.  
Shaker Needle inside Jet should rattle.  
Preheat and run stove.  
If performance does not improve, perform  
Cleaning the Jet and Fuel Line steps.



**1. Clean the Jet and Fuel Line reduce fuel flow and import stove performance.**  
Minor deposits in the Jet can be cleared with the Shaker Needle. Major deposits  
may require extensive cleaning of the jet and fuel line.

## PUMP MAINTENANCE

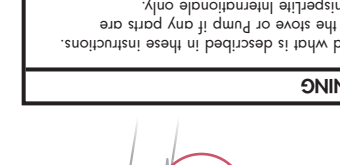

**REPLACING PUMP SEAL**  
Inspect Pump Seal and replace if  
damaged.  
Remove O-ring with Safety Pin.  
Slide Stop Nut off.  
Remove Control Valve handle  
from stem.  
Inspect O-ring and replace if damaged.  
Unscrew Stop Nut completely and  
remove Control Valve Assembly.  
Unscrew Control Valve 6 turns.  
Unscrew Stop Nut 2 turns.

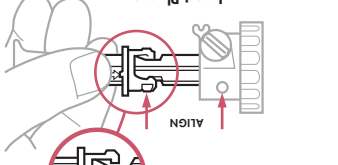

**REPLACING FUEL TUBE O-RING**  
1. Remove Plunger.  
Align, twist, and pull.  
Remove Fuel Tube Bushing and O-ring  
with Jet and Cable Tool.  
Remove the O-ring with the end of the  
Fuel Line or Safety Pin.  
Inspect O-ring and replace if damaged.  
If needed, a spare red Fuel Tube  
O-ring is provided.  
Use a drop of Pump Cup Oil or any  
mineral-based oil.  
Hold thumb and forefinger firmly  
around Arrow 1.  
Align Plunger Bushing Tabs with  
holes in Pump Body.  
Push Plunger/Bushing into the  
Pump Body until it snaps in place.



**CLEANING THE CHECK VALVE**  
1. Turn Check Valve Assembly to remove.  
2. Wipe any debris from Check Valve  
and Pump Cavity.  
3. Reinsert Check Valve Assembly.



**REPLACING CONTROL VALVE O-RING**  
1. Unscrew Stop Nut 2 turns.  
2. Unscrew Control Valve 6 turns.  
3. Unscrew Stop Nut completely and  
remove Control Valve Assembly.  
4. Inspect O-ring and replace if damaged.  
Remove Control Valve handle  
from stem.  
Slide Stop Nut off.  
Remove O-ring with Safety Pin.  
Inspect Pump Seal and replace if  
damaged.



**REPLACING CONTROL VALVE O-RING**  
1. Unscrew Stop Nut 2 turns.  
2. Unscrew Control Valve 6 turns.  
3. Unscrew Stop Nut completely and  
remove Control Valve Assembly.  
4. Inspect O-ring and replace if damaged.  
Remove Control Valve handle  
from stem.  
Slide Stop Nut off.  
Remove O-ring with Safety Pin.  
Inspect Pump Seal and replace if  
damaged.



**REPLACING CONTROL VALVE O-RING**  
1. Unscrew Stop Nut 2 turns.  
2. Unscrew Control Valve 6 turns.  
3. Unscrew Stop Nut completely and  
remove Control Valve Assembly.  
4. Inspect O-ring and replace if damaged.  
Remove Control Valve handle  
from stem.  
Slide Stop Nut off.  
Remove O-ring with Safety Pin.  
Inspect Pump Seal and replace if  
damaged.

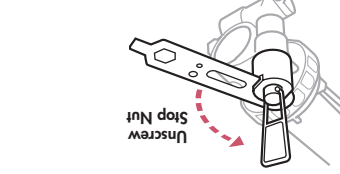

**REPLACING CONTROL VALVE O-RING**  
1. Unscrew Stop Nut 2 turns.  
2. Unscrew Control Valve 6 turns.  
3. Unscrew Stop Nut completely and  
remove Control Valve Assembly.  
4. Inspect O-ring and replace if damaged.  
Remove Control Valve handle  
from stem.  
Slide Stop Nut off.  
Remove O-ring with Safety Pin.  
Inspect Pump Seal and replace if  
damaged.

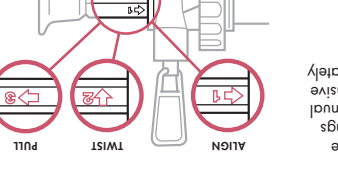

**REPLACING CONTROL VALVE O-RING**  
1. Unscrew Stop Nut 2 turns.  
2. Unscrew Control Valve 6 turns.  
3. Unscrew Stop Nut completely and  
remove Control Valve Assembly.  
4. Inspect O-ring and replace if damaged.  
Remove Control Valve handle  
from stem.  
Slide Stop Nut off.  
Remove O-ring with Safety Pin.  
Inspect Pump Seal and replace if  
damaged.

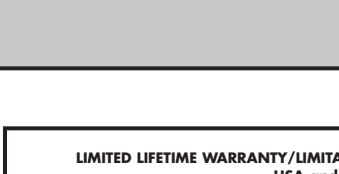

**REPLACING CONTROL VALVE O-RING**  
1. Unscrew Stop Nut 2 turns.  
2. Unscrew Control Valve 6 turns.  
3. Unscrew Stop Nut completely and  
remove Control Valve Assembly.  
4. Inspect O-ring and replace if damaged.  
Remove Control Valve handle  
from stem.  
Slide Stop Nut off.  
Remove O-ring with Safety Pin.  
Inspect Pump Seal and replace if  
damaged.

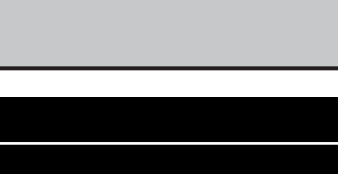

**REPLACING CONTROL VALVE O-RING**  
1. Unscrew Stop Nut 2 turns.  
2. Unscrew Control Valve 6 turns.  
3. Unscrew Stop Nut completely and  
remove Control Valve Assembly.  
4. Inspect O-ring and replace if damaged.  
Remove Control Valve handle  
from stem.  
Slide Stop Nut off.  
Remove O-ring with Safety Pin.  
Inspect Pump Seal and replace if  
damaged.

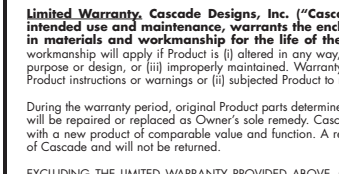

**REPLACING CONTROL VALVE O-RING**  
1. Unscrew Stop Nut 2 turns.  
2. Unscrew Control Valve 6 turns.  
3. Unscrew Stop Nut completely and  
remove Control Valve Assembly.  
4. Inspect O-ring and replace if damaged.  
Remove Control Valve handle  
from stem.  
Slide Stop Nut off.  
Remove O-ring with Safety Pin.  
Inspect Pump Seal and replace if  
damaged.



**REPLACING CONTROL VALVE O-RING**  
1. Unscrew Stop Nut 2 turns.  
2. Unscrew Control Valve 6 turns.  
3. Unscrew Stop Nut completely and  
remove Control Valve Assembly.  
4. Inspect O-ring and replace if damaged.  
Remove Control Valve handle  
from stem.  
Slide Stop Nut off.  
Remove O-ring with Safety Pin.  
Inspect Pump Seal and replace if  
damaged.

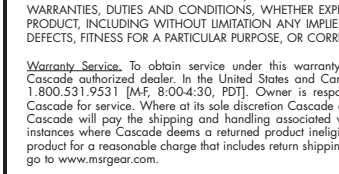

**REPLACING CONTROL VALVE O-RING**  
1. Unscrew Stop Nut 2 turns.  
2. Unscrew Control Valve 6 turns.  
3. Unscrew Stop Nut completely and  
remove Control Valve Assembly.  
4. Inspect O-ring and replace if damaged.  
Remove Control Valve handle  
from stem.  
Slide Stop Nut off.  
Remove O-ring with Safety Pin.  
Inspect Pump Seal and replace if  
damaged.



**REPLACING CONTROL VALVE O-RING**  
1. Unscrew Stop Nut 2 turns.  
2. Unscrew Control Valve 6 turns.  
3. Unscrew Stop Nut completely and  
remove Control Valve Assembly.  
4. Inspect O-ring and replace if damaged.  
Remove Control Valve handle  
from stem.  
Slide Stop Nut off.  
Remove O-ring with Safety Pin.  
Inspect Pump Seal and replace if  
damaged.

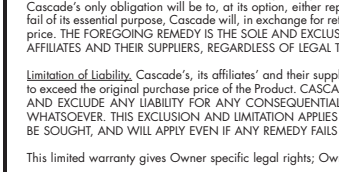

**REPLACING CONTROL VALVE O-RING**  
1. Unscrew Stop Nut 2 turns.  
2. Unscrew Control Valve 6 turns.  
3. Unscrew Stop Nut completely and  
remove Control Valve Assembly.  
4. Inspect O-ring and replace if damaged.  
Remove Control Valve handle  
from stem.  
Slide Stop Nut off.  
Remove O-ring with Safety Pin.  
Inspect Pump Seal and replace if  
damaged.



**REPLACING CONTROL VALVE O-RING**  
1. Unscrew Stop Nut 2 turns.  
2. Unscrew Control Valve 6 turns.  
3. Unscrew Stop Nut completely and  
remove Control Valve Assembly.  
4. Inspect O-ring and replace if damaged.  
Remove Control Valve handle  
from stem.  
Slide Stop Nut off.  
Remove O-ring with Safety Pin.  
Inspect Pump Seal and replace if  
damaged.

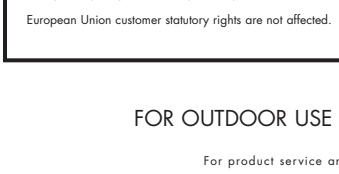

**REPLACING CONTROL VALVE O-RING**  
1. Unscrew Stop Nut 2 turns.  
2. Unscrew Control Valve 6 turns.  
3. Unscrew Stop Nut completely and  
remove Control Valve Assembly.  
4. Inspect O-ring and replace if damaged.  
Remove Control Valve handle  
from stem.  
Slide Stop Nut off.  
Remove O-ring with Safety Pin.  
Inspect Pump Seal and replace if  
damaged.



**REPLACING CONTROL VALVE O-RING**  
1. Unscrew Stop Nut 2 turns.  
2. Unscrew Control Valve 6 turns.  
3. Unscrew Stop Nut completely and  
remove Control Valve Assembly.  
4. Inspect O-ring and replace if damaged.  
Remove Control Valve handle  
from stem.  
Slide Stop Nut off.  
Remove O-ring with Safety Pin.  
Inspect Pump Seal and replace if  
damaged.



**REPLACING CONTROL VALVE O-RING**  
1. Unscrew Stop Nut 2 turns.  
2. Unscrew Control Valve 6 turns.  
3. Unscrew Stop Nut completely and  
remove Control Valve Assembly.  
4. Inspect O-ring and replace if damaged.  
Remove Control Valve handle  
from stem.  
Slide Stop Nut off.  
Remove O-ring with Safety Pin.  
Inspect Pump Seal and replace if  
damaged.



**REPLACING CONTROL VALVE O-RING**  
1. Unscrew Stop Nut 2 turns.  
2. Unscrew Control Valve 6 turns.  
3. Unscrew Stop Nut completely and  
remove Control Valve Assembly.  
4. Inspect O-ring and replace if damaged.  
Remove Control Valve handle  
from stem.  
Slide Stop Nut off.  
Remove O-ring with Safety Pin.  
Inspect Pump Seal and replace if  
damaged.

## FUEL INFORMATION

The WhisperLite Internationale™ burns a variety of fuels by using two interchangeable Jets.

- The IG Jet is used for White Gas and Unleaded Auto Gas. This Jet is preinstalled in your stove.
- The K Jet is for Kerosene and Diesel. This Jet is included in the parts kit with your stove.  
To exchange Jets, see "Cleaning the Jet and Fuel Line."

Use MSR® SuperFuel™ (White Gas) for optimal performance. It is the highest quality fuel available for your stove. Do not use leaded fuels. Fuels other than MSR SuperFuel lead to rapid stove clogging and require more frequent Jet and Fuel Line cleanings. Also, the use of Unleaded Auto Gas may shorten stove lifespan. Use the fuels chart below to help you find your fuel when traveling internationally.

Visit [www.msrgear.com](http://www.msrgear.com) for more information on international fuel names and safe stove transportation.

USA/UK/Canada	Germany/Switzerland	Japan	France	Netherlands	Spain
White Gas, Naphtha	Kocherbenzin, Reinbenzin	White Gas	Pétrole à brûler, Essence C	Wasbenzine	Bencina blanca
Unleaded Auto Gas	Autobenzin	Gasoline	Essence sans plomb	Benzine	Gasolina sin plomo
Kerosene	Petroleum	Toh-yu	Kérosène	Petroleum Lampolie	Parafina
Diesel	Diesel	Diesel	Diesel	Diesel	Diesel

## TROUBLESHOOTING

Problem	Cause	Solution
<b>Leaking Fuel</b>		
At Pump and Fuel Bottle Connection	Damaged or missing Pump Seal	Replace Pump Seal
At Pump and Fuel Line Connection	Damaged or missing Fuel Tube O-ring	Replace Fuel Tube O-ring
At Control Valve Stem	Damaged or missing Control Valve O-ring	Replace Control Valve O-ring
In Pump Plunger Chamber	Obstructed Check Valve	Clean Check Valve Cavity
<b>Poor Performance</b>		
Pump not pressurizing Fuel Bottle	Loose or poorly seated Pump	Tighten or rescrew Pump on Fuel Bottle
	Damaged Pump Cup	Replace Pump Cup
Plunger hard to pump	Dry Pump Cup	Lubricate Pump Cup
Erratic yellow flames	Improper preheating	Repeat <b>Step 4</b>
Diminished flames	Low Fuel Bottle pressure	Pump the Plunger
Slow boil times	Clogged Jet or Fuel Line	Clear Jet and clean Fuel Line
Diminished flames at altitude	Insufficient airflow	Open Windscreen slightly

## DANGER



### CARBON MONOXIDE, FIRE & EXPLOSION HAZARD

This stove is for **OUTDOOR USE ONLY**. Do not use stove in a tent, car, house, or inside any enclosed area. This stove consumes oxygen. Using it in an enclosed area will cause carbon monoxide poisoning and death.

Do not use a stove that has a fuel leak. This stove uses highly flammable fuel. Leaking fuel can easily ignite and cause fire, serious burns, property damage, personal injury, and death.

Keep fuel bottle away from stove burner and other heat sources. This stove uses a sealed fuel bottle that can explode when exposed to extreme heat. An explosion can cause serious burns, property damage, personal injury, and death.

READ, UNDERSTAND, AND FOLLOW ALL instructions and warnings in this manual before using this stove.

Failure to follow all warnings and instructions can result in property damage, serious injury, or death.

**See inside for detailed instructions.**

### LIMITED LIFETIME WARRANTY/LIMITATIONS OF REMEDIES AND LIABILITY USA and Canada

**Limited Warranty.** Cascade Designs, Inc. ("Cascade") to the original owner ("Owner"), under intended use and maintenance, warrants the enclosed product ("Product") to be free from defects in materials and workmanship for the life of the Product. No warranty against defects in materials and workmanship will apply if Product is (i) altered in any way, (ii) used for purposes inconsistent with Product's intended purpose or design, or (iii) improperly maintained. Warranty will furthermore be voided where user (i) failed to follow Product instructions or warnings or (ii) subjected Product to misuse, abuse, or neglect.

During the warranty period, original Product parts determined by Cascade to be defective in materials or workmanship will be repaired or replaced as Owner's sole remedy. Cascade reserves the right to replace any discontinued product with a new product of comparable value and function. A returned product deemed irreparable becomes the property of Cascade and will not be returned.

EXCLUDING THE LIMITED WARRANTY PROVIDED ABOVE, CASCADE, ITS AFFILIATES AND THEIR SUPPLIERS, TO THE MAXIMUM EXTENT PERMITTED BY LAW, MAKE NO WARRANTIES, EXPRESSED OR IMPLIED, AND DISCLAIM ALL WARRANTIES, DUTIES AND CONDITIONS, WHETHER EXPRESSED, IMPLIED, OR STATUTORY, WITH RESPECT TO THE PRODUCT, INCLUDING WITHOUT LIMITATION ANY IMPLIED WARRANTIES OF MERCHANTABILITY, AGAINST LATENT DEFECTS, FITNESS FOR A PARTICULAR PURPOSE, OR CORRESPONDENCE TO DESCRIPTION.

**Warranty Service.** To obtain service under this warranty, the warranty-eligible Product must be presented to a Cascade authorized dealer. In the United States and Canada, warranty service may also be obtained by calling 1.800.531.9531 [M-F, 8:00-4:30, PDT]. Owner is responsible for all costs associated with returning Product to Cascade for service. Where at its sole discretion Cascade deems Product eligible for warranty repair or replacement, Cascade will pay the shipping and handling associated with returning repaired or replaced Product to Owner. In instances where Cascade deems a returned product ineligible for warranty service, Cascade will, if possible, repair product for a reasonable charge that includes return shipping and handling. For warranty return service details, please go to [www.msrgear.com](http://www.msrgear.com).

**Limitation of Remedies.** Should a court of competent jurisdiction find the limited warranty set forth above breached, Cascade's only obligation will be to, at its option, either repair or replace Product. Should the aforementioned remedy fail of its essential purpose, Cascade will, in exchange for return of Product, refund to Owner Product's original purchase price. THE FOREGOING REMEDY IS THE SOLE AND EXCLUSIVE REMEDY OF THE PURCHASER AGAINST CASCADE, ITS AFFILIATES AND THEIR SUPPLIERS, REGARDLESS OF LEGAL THEORY.

**Limitation of Liability.** Cascade's, its affiliates' and their suppliers' maximum liability is limited to incidental damages not to exceed the original purchase price of the Product. CASCADE, ITS AFFILIATES AND THEIR SUPPLIERS HEREBY DISCLAIM AND EXCLUDE ANY LIABILITY FOR ANY CONSEQUENTIAL OR OTHER DAMAGES RESULTING FROM ANY REASON WHATSOEVER. THIS EXCLUSION AND LIMITATION APPLIES TO ALL LEGAL THEORIES UNDER WHICH DAMAGES MAY BE SOUGHT, AND WILL APPLY EVEN IF ANY REMEDY FAILS OF ITS ESSENTIAL PURPOSE.

This limited warranty gives Owner specific legal rights; Owner may have additional rights, which vary state to state. Always completely follow safety, use, operation, and maintenance instructions for this or any other Cascade product. European Union customer statutory rights are not affected.

FOR OUTDOOR USE ONLY  

For product service and information contact  
**Cascade Designs, Inc.®**  
4000 First Avenue South, Seattle, WA 98134 USA  
Phone: 800.531.9531 or 206.505.9500  
[www.msrgear.com](http://www.msrgear.com)

# INSTRUCTION MANUAL



**MSR®**  
MOUNTAIN SAFETY RESEARCH®

**ENG**

## WHISPERLITE INTERNATIONALE™

119621-2

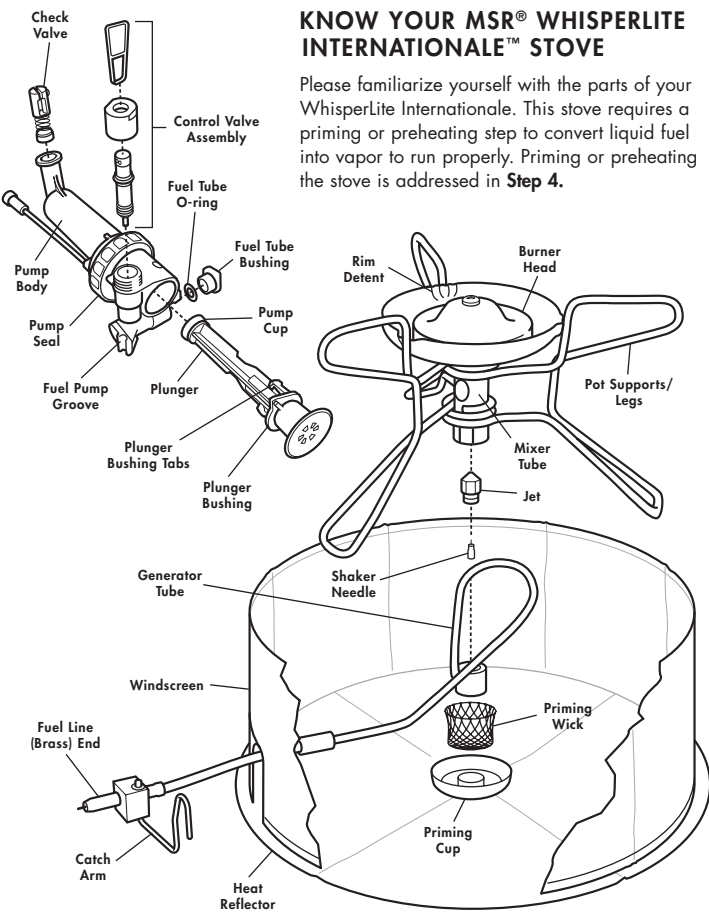

## KNOW YOUR MSR® WHISPERLITE INTERNATIONALE™ STOVE

Please familiarize yourself with the parts of your WhisperLite Internationale. This stove requires a priming or preheating step to convert liquid fuel into vapor to run properly. Priming or preheating the stove is addressed in **Step 4**.

## WHISPERLITE INTERNATIONALE OPERATING INSTRUCTIONS

READ, UNDERSTAND, AND FOLLOW ALL instructions and warnings in this manual before using this stove.

### 1 PREPARE FUEL BOTTLE

The WhisperLite Internationale is sold with two interchangeable Jets so it can burn a variety of fuels. To ensure the correct Jet is installed for the type of fuel to be used, see *Fuel Information*.

1. **Fill Fuel Bottle to fill line only.**  
Air space is necessary for fuel expansion.
2. **Insert Pump into Fuel Bottle and firmly tighten.**
3. **Close the Pump Control Valve, then stroke Plunger (20-30 strokes).**  
Less fuel requires more strokes or pressure. Pump until firm resistance is felt.

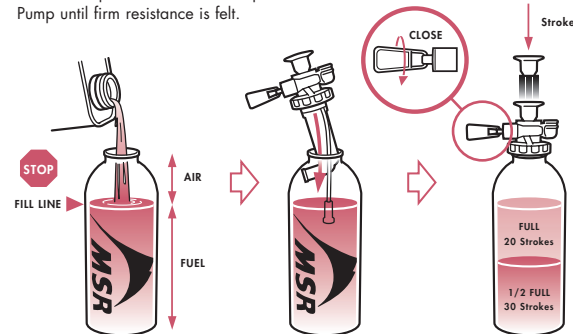

#### ⚠ WARNING

Use MSR fuel bottles only. Non-MSR fuel bottles may leak fuel, causing fire and injury. Keep children away from stove and fuel. Never leave a burning or hot stove unattended.

### 2 SET UP STOVE

1. **Unfold the 3 Pot Supports/Legs.**  
Snap each Pot Support/Leg into a rim detent.
2. **Place stove on the center of Heat Reflector.**

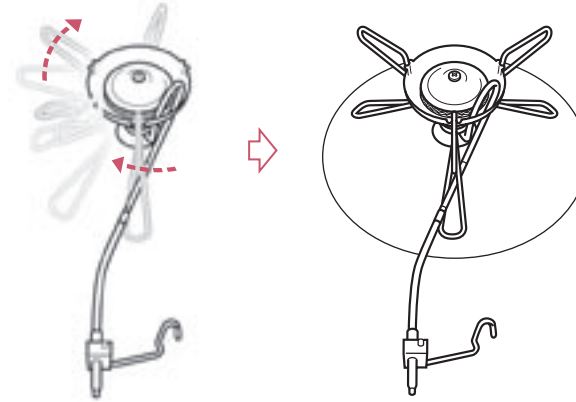

#### ⚠ WARNING

Keep combustibles at least 4 feet (1.2 meters) away from the top and sides of a burning stove. This stove can ignite combustible materials. Use this stove for cooking food and boiling water only. Never use it for any other purpose. When temperatures are below -10 F (-24 C), O-rings may be stiff and prone to fuel leakage. Use extreme caution in temperatures below freezing.

### 3 CONNECT STOVE AND PUMP

1. **Lubricate the entire brass end of the Fuel Line with saliva or oil.**
2. **Completely insert the brass end of the Fuel Line into Pump.**  
Place Fuel Bottle on its side so Pump Control Valve points up.
3. **Secure the Catch Arm on Fuel Pump Groove.**  
Keep Fuel Line straight for safety.  
Keep Fuel Bottle as far away as possible from stove.

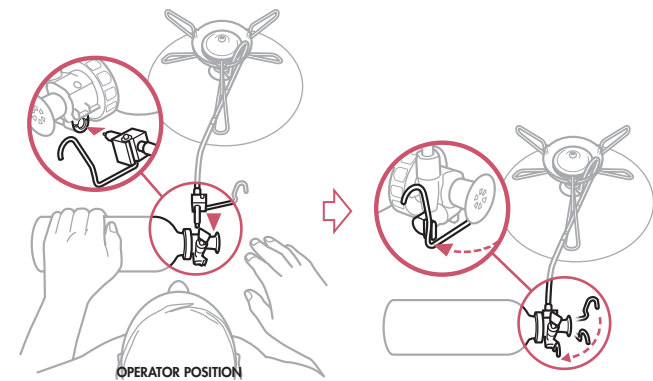

#### ⚠ WARNING

Before every use, look for fuel on the Fuel Bottle, Pump, Fuel Line, and Burner. Do not light the stove if you see or smell fuel. See *Troubleshooting*. Never disconnect the Fuel Line, Pump, or Fuel Bottle when the stove is in use or fuel will leak, ignite, and burn you. Leaking or spilled fuel may ignite and burn you.

### 4 PREHEAT STOVE

1. **Release only 1/2 spoonful of fuel.**  
Open Pump Control Valve 1.5 turns and let fuel flow through the Jet.  
Close Pump Control Valve.  
Look for fuel in Priming Cup and on Wick.
2. **Light fuel in the Priming Cup.**  
A brief soccer ball-size flame is normal.

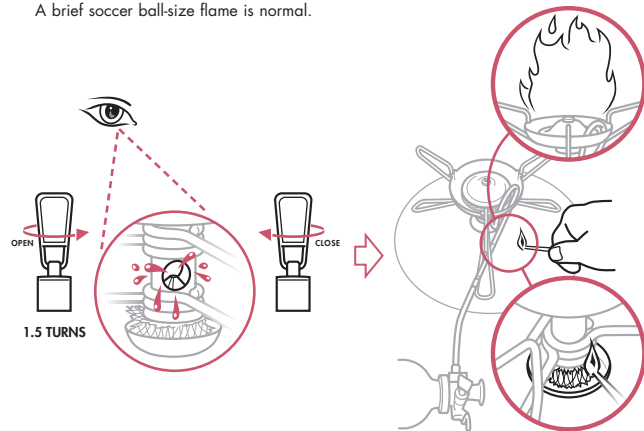

#### ⚠ WARNING

Never place your head or body above the stove when lighting it or while stove is burning. Never use excess fuel to preheat stove. Leaking or spilled fuel may ignite and burn you.

### 5 TURN STOVE ON

1. **Wait for preheat flame to reduce in size (approximately 2 minutes).**  
If flame goes out, wait 5 minutes for stove to cool before relighting.
2. **Open Pump Control Valve 1/2 turn and wait for steady blue flame.**
3. **Slowly open Pump Control Valve.**

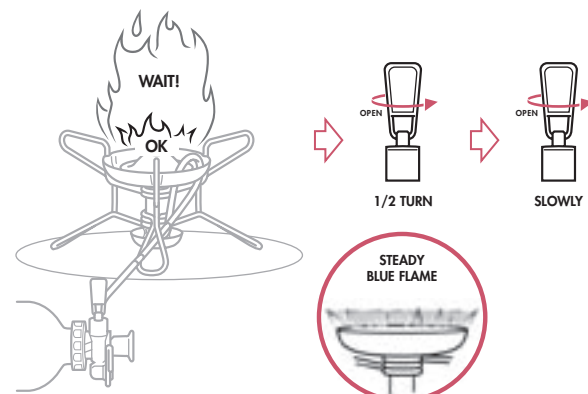

#### ⚠ WARNING

Relighting a warm stove may cause large flames that can burn you. Let the stove cool 5 minutes before relighting. Accessible parts may be very hot. Never move a hot or burning stove.

### 6 USE STOVE TO COOK

1. **Set up Windscreen.**  
Fold the ends of Windscreen together.  
Leave a 1/2-inch (2.5-cm) gap between Windscreen and pot for optimal performance.  
Use Windscreen to improve performance in all conditions.
2. **Place pot on stove.**
3. **Maintain Fuel Bottle pressure.**  
Add approximately 10 strokes every 10 minutes to maintain performance.  
Hold Fuel Bottle firmly while pumping.

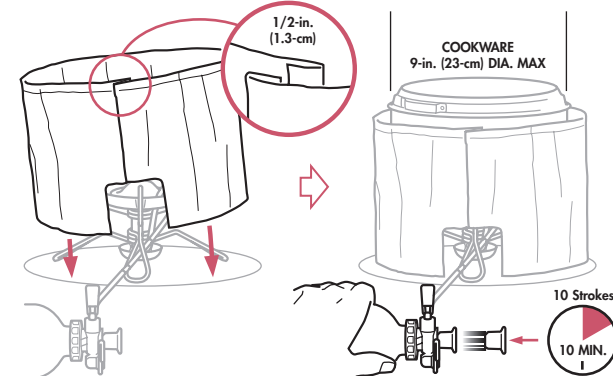

#### ⚠ WARNING

Keep the Fuel Bottle away from the stove burner or other heat sources. Separate Burner and Fuel Bottle with the Windscreen. An overheated Fuel Bottle can explode and burn or injure you. Never use cookware with a diameter greater than 9 inches (23 centimeters). Large cookware reflects excessive heat. Never operate stove with empty or dry pots. Never use non-MSR reflectors or diffusers.

### 7 TURN STOVE OFF

1. **Close Pump Control Valve.**  
Residual fuel will continue to burn with a small flame.
2. **After flames are out, wait 5 minutes for stove to cool.**
3. **Unlock Catch Arm and remove Fuel Line from Pump.**
4. **Depressurize Fuel Bottle and repack stove.**  
Hold the Fuel Bottle upright, away from your face and any sources of heat or ignition.  
Slowly unscrew pump to depressurize Fuel Bottle.  
To transport or store the Fuel Bottle, the Pump may be left inside a depressurized Fuel Bottle. The Pump can also be removed and replaced with the Fuel Bottle Cap.

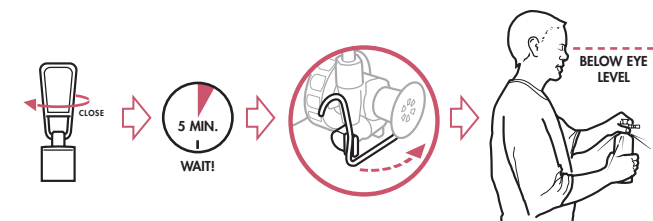

#### ⚠ WARNING

Do not store Fuel Bottle near heat or ignition sources, such as water heaters, stoves, pilot lights, furnaces, and electrical devices. Keep the Fuel Bottle tightly closed in a cool, well-ventilated place. Use extreme caution when storing stove fuel.